

Ultra-low Power 8-Channels Switch Control FSK Transceiver Module

SPECIFICATION

Model No.: DL-A7149K8

Version No.: V1.0

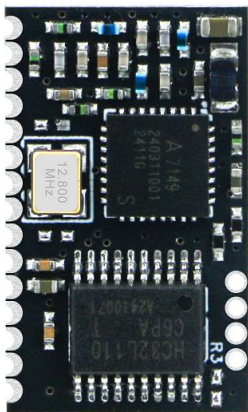

DL-A7149K8-TX

433/868/915MHz

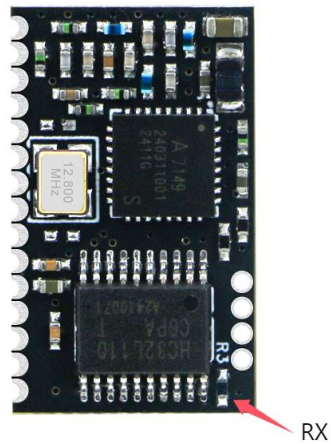

DL-A7149K8-RX

433/868/915MHz

Before using this product, please pay attention to the following important matters:

This RF module is an electrostatic sensitive product. Please operate it on an anti-static workbench during installation and testing.

This RF module requires an external antenna by default, which is intended to be embedded in your product or application. The antenna can be a wire antenna or a standard UHF antenna. You can choose a specific antenna according to the actual situation.

Metal objects and wires should be kept away from the antenna as much as possible. If the product uses a metal shell, be sure to install the antenna outside the metal shell. Otherwise, the RF signal will be seriously attenuated, which will affect the effective distance.

Disclaimer:

This specification is just for your information, all the charts and pictures used in this specification are for reference only. The actual test shall prevail for details. We do not assume any responsibility for personal injury or property loss caused by user's improper operation.

This specification is subject to change due to the continuous improvement and upgrading of the product version, and the latest version specification shall prevail. DREAMLNK reserves the right of final interpretation and modification of all contents in this specification.

Revision History

Date	Version	Formulation / Revision of Contents	Approved by
2024-08-01	V1.0	Standard Version DL-A7149K8 RF Module	Fagan Xu

Copyright © Shenzhen DreamLnk Technology Co., Ltd

1. Module Introduction

1.1 Brief Introduction

The DL-A7149K8 Wireless Module is a cost-effective, compact size, high sensitivity, long-range, multi-channel switch control FSK Transceiver Module developed by DreamLNK. It is no need to design complex underlying driver software, also no need to define the transceiver communication protocol, nor the key value definition. We have already optimized its code matching, remote control, low power consumption, and Co-frequency Interference capability. You just need to connect the necessary input buttons and output loads, code matching button, code matching indicator, etc. Then it can be used without any programming.

There are 2 versions DL-A7149K8 RF modules, the DL-A7149K8-TX one is a transmitter module, while DL-A7149K8-RX version is the receiver module. After triggering, the TX module automatically enters sleep mode, while the RX module has normal mode and WoR (low-power) mode, which were specifically designed for battery powered systems to achieve wireless receiving functionality and low-power requirements.

These Switch Control RF Modules can be triggered by high and low levels: after the transmission mode button is triggered, the corresponding output port of the receiver module can output a level signal. The standard RF module has 8 independent control signals. The 8 buttons on the transmitter correspond to the 8 signal outputs of the receiver module. It can realize single-channel remote control, as well as multi-channels remote control simultaneously.

This Wireless Module is compact in size, low in power consumption, and easy to use. The transmitter module only needs to design the key board according to the remote-control shell. The receiver module has no peripheral parts. The signal of the I/O ports can directly drive small loads such as LEDs, motors, and relays. These 8 output signals can also be provided as parallel level signals to the I/O port of the MCU for use. It is very convenient and simple to use, and multiple sets of products can be used simultaneously without interfering with each other.

***Note:** these RF modules will be sold base on our standard firmware. For specific requirements, please feel free to contact us. Customized firmware can be also realized with a certain MOQ.*

1.2 Features

- Frequency Bands: 433Mhz/868MHz/915MHz;
- RX can choose between normal mode and WOR mode to reduce the average receiving current;
- It adopts code hopping and random frequency allocation to reduce the risk of fixed frequency interference;
- Highly integrated, small size, ultra-low power design, suitable for low-power application scenarios;
- Support multi-ID storage, the receiver module can store up to 20 different IDs, making it easy to manage the access and control of multiple transmitting devices;
- Multi-channel independent control, 8-channel switch output, support single or multiple channel simultaneous control, can meet complex remote-control requirements;
- Easy to use, no programming required, users only need to connect the required peripheral devices such as buttons and loads to use.

1.3 Typical application

- Multi-channel controller for electric vehicles
- Multi-channel input and output switch control
- Multi-channel lighting fixtures remote control
- AMR system (Wireless meter reading)
- Wireless multi-channel opening and closing controller
- Multi-channel level control circuit
- Smart buildings, Smart home
- Intelligent switch

2. Technical Parameter

Parameter	Min.	Typical	Max.	Unit	Remarks
Operating Conditions					
Working Voltage	2.2	3.3	3.6	V	To ensure maximum chip power, stable voltage should $\geq 3.2V$
Communication Level Range	-0.3	3.3	3.6	V	Out range may damage the chip
Working Temperature Range	-40	25	85	$^{\circ}C$	The larger the temperature difference, the greater the required bandwidth
Current Consumption					
Receiving Current @ Normal Mode	2.5	3.5	4.2	mA	WoR mode can effectively reduce the overall working current
WOR Mode (Low Power Mode)		100		μA	In WoR mode, RX wake-up detection is performed once every 500mS, with an average standby current of about 100 μA (sleep time can be customized, and the longer the sleep time, the lower the power consumption)
TX Current	87	107	127	mA	@433MHz 19dBm
	78	98	118	mA	@868MHz/915MHz 17dBm
Sleep Current		2.5		μA	
RF Parameters					
Transmitting Power		19		dBm	433M
		17		dBm	868/915M
Receiving Sensitivity		-115 -113 -111		dBm	@433MHz, 10Kbps, IFBW:50KHz @868MHz, 10Kbps, IFBW:50KHz @915MHz, 10Kbps, IFBW:50KHz

Table 1: Technical Parameter

3. Pin Definitions

DL-A7149K8-TX RF Module

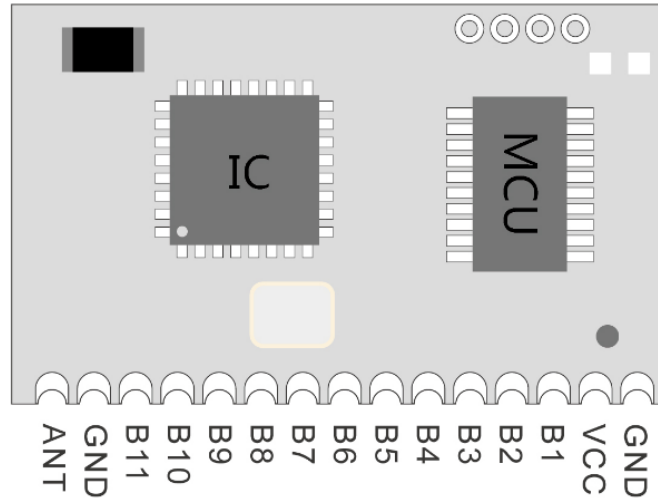

Figure 1: DL-A7149K8-TX Pins Diagram

Pin No	Pin's Name	Type	Description
1	GND	PWR	Reliable grounding
2	VCC	PWR	Power supply
3	B1-B8	I	8-channel data pin, Low level trigger, transmit button active (When TX at low level, RX will at high level)
4	B9	I	Low level trigger, enters code pairing state
5	B10	I	Indicator pin (code matching, transmitting status), for LED connecting
6	B11	I	High level uses 4Byte preamble, low level uses 64Byte preamble (Long preamble can effectively WoR low-power mode) Note: long preamble also takes a long time to send
7	VCC	PWR	3.3V
8	ANT/NC	AI/AO	Analog antenna Input/output interface, 50Ω impedance, make it grounded, and add via holes

Table 2: DL-A7149K8-TX Pins Definitions

DL-A7149K8-RX RF Module

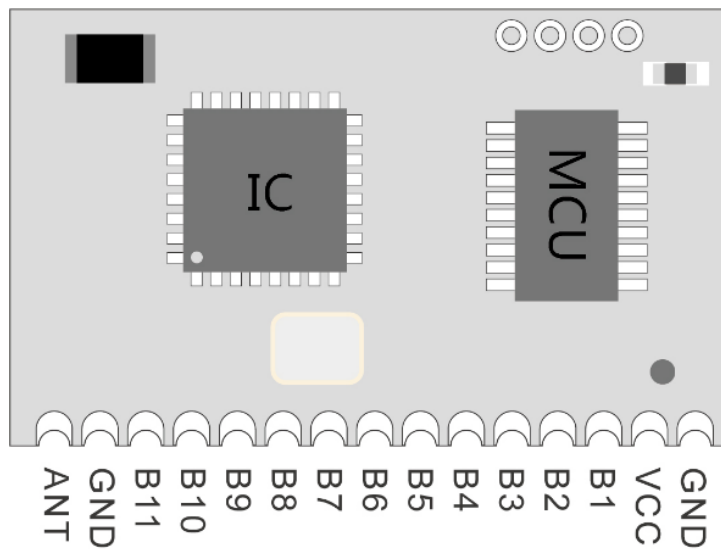

Figure 2: DL-A7149K8-RX Pins Diagram

Pin No	Pin's Name	Type	Description
1	GND	PWR	Reliable grounding
2	VCC	PWR	Power supply
3	B1-B8	0	8-channel data output pin, high level output, (B8 will be multiplexed as coding indicator pin) (When TX at low level, RX will at high level)
4	B9	I	Low level trigger, enters code pairing state
5	B10	I	WoR mode / Normal mode (High level: WoR mode, low level: Normal mode)
6	B11	I	Output mode selection. Set low level (0) for Latch Mode, set high level (1) for Inching Mode (momentary control)
7	GND	PWR	Reliable grounding
8	ANT/NC	AI/AO	Analog antenna Input/output interface, 50Ω impedance, make it grounded, and add via holes

Table 3: DL-A7149K8-RX Pins Definitions

Remark: The receiver module can provide a maximum output current of 22mA. If driving other large loads (which requires heavy current), a driving circuit needs to be added.

4. Module Size

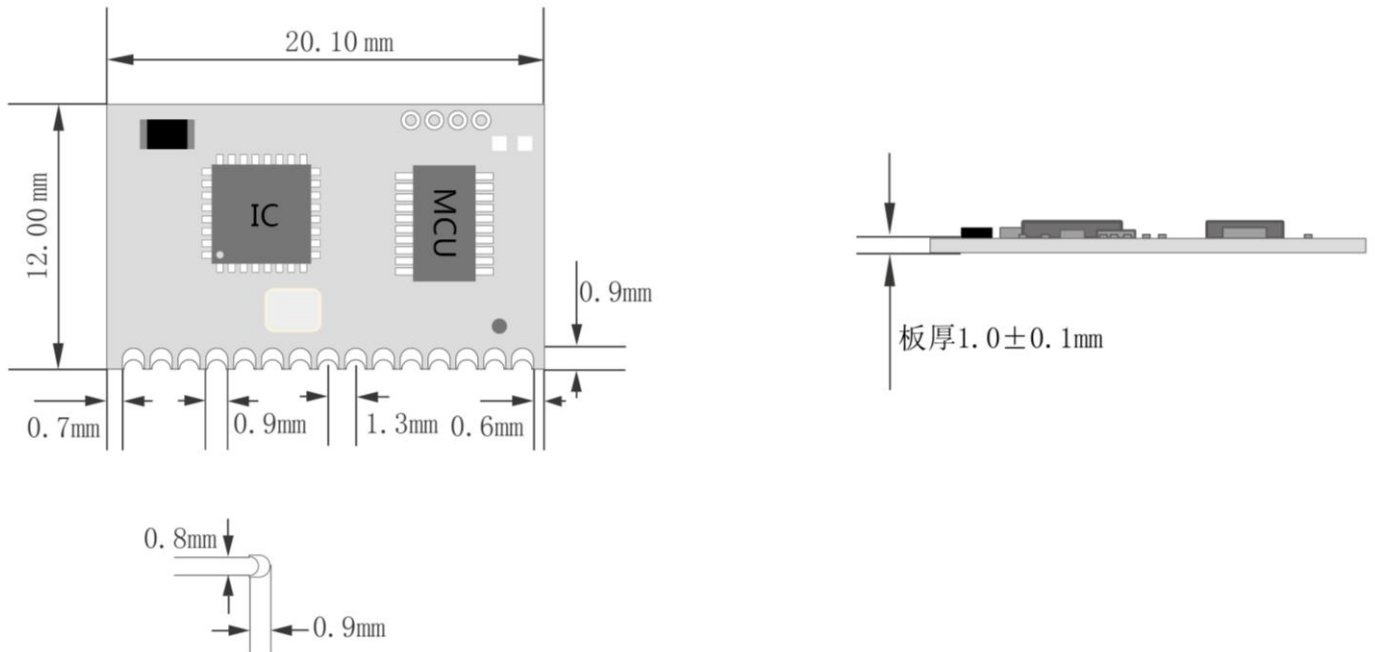

Figure 3: DL-A7149K8 RF Module Dimensions
(Note: the TX transmitter module and RX receiver module have the same size)

5. Application Connection Diagram

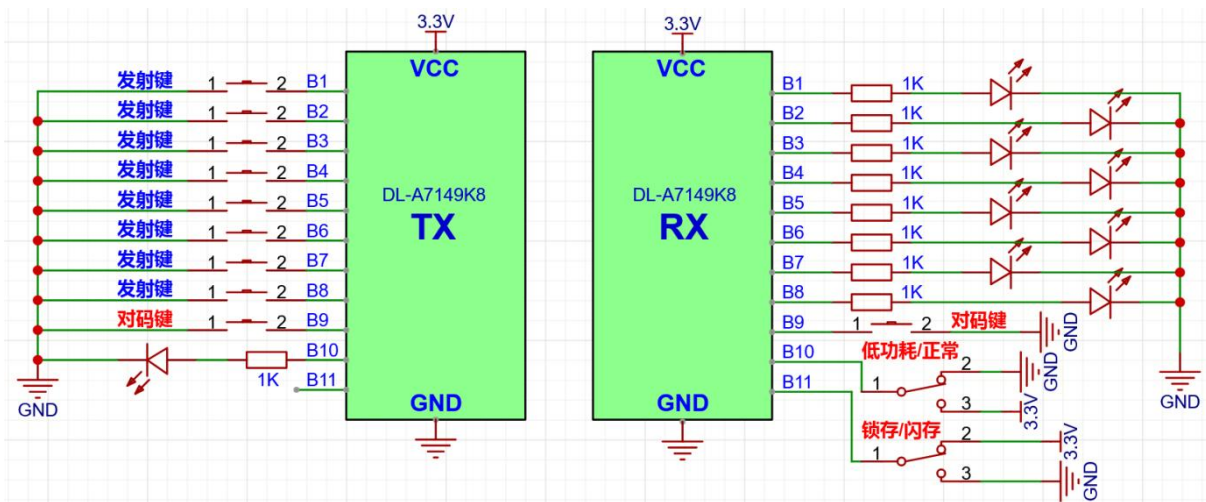

Figure 4: Application Connection Diagram

Note: the TX and RX modules can be distinguished by R3, the TX module part is NC, while the RX module part has a resistor here. R3 is only used to distinguish between TX and RX modules.

6. RX Module Conversion

Mode	Description
Normal Mode	Set B10 to low-level , RF module enters normal working mode
WOR Mode (Low Power Mode)	Set B10 to high-level , RF module enters WOR Mode. In WOR Mode, the module is periodically awakened and detected by the microcontroller to check for the presence of carrier signals. Once a carrier signal is detected, the RF chip will begin processing the received data. If no carrier signal is detected, the RF chip will immediately return to sleep mode and output a low-level signal. To avoid signal loss when the receiving module is in sleep mode, it is recommended to extend the remote control's code transmission time to 1 to 2 seconds, connect B2 to VCC and enter WoR mode, with an average standby current of around 150uA.
Inching Mode (Momentary Control)	Set B11 to high-level , RF module enters Inching Mode . In Inching Mode, press and hold the transmit button, and the receiver will output a high level after receiving data. Release the button, and the receiver will change to a low level.
Latch Mode (Latched Control)	Set B11 to low-level , RF module enters Latch Mode , the RX output port is usually in a low-level state. Press the transmit button once to receive the high-level output and latch it. Press the button again, the receiver will change to a low level.

Table 4: RX Module Conversion

7. Code Pairing and Pin Setting

The RX module can only be used after code pairing. In order to solve the problem of Co-frequency interference when multiple RX devices are used in the same environment, this DL-A7149K8-RX module adopts the method of code hopping and random frequency allocation. Therefore, successful code pairing is a must. The RX module supports storing up to 20 different IDs. After exceeding 20 IDs, the subsequent IDs will automatically overwrite the previously saved IDs.

Clear the Pairing: please lower the B9 pin for 8 seconds, to make the RX module enter **Clear Pairing Mode**, until the B8 port LED light flashes 3 times to complete the code clearing process.

(Note: all IDs saved by the RX will be cleared. After clearing the Pairing, this RX module needs to

re-code before it can be used).

Coding/Pairing Description:

1. RX Pairing: pull B9 Pin down (low-level) for 5 seconds under normal working conditions, the RX enters pairing mode; after the module enters the pairing state, the pairing indicator light B8 stays on and waits for pairing. At this time, presses the button on TX end (while in pairing state); after RX pairing, the pairing indicator light B8 port LED flashes 3 times, indicating they are successful paired. RX module exits the pairing state, B8 light goes out, and pairing is completed.

If the code indicator light B8 stays on for 12 seconds and then automatically turns off, the module will automatically exit the code pairing state (code pairing timeout), indicating that the code pairing was not successful or that TX did not press the button in the code pairing state.

Note: if the receiver module (RX) is replaced after coding, the original remote control (TX) needs to be coded again.

2. TX Pairing: pull B9 Pin down (low-level) for 5 seconds under normal working conditions, the TX enters pairing mode, and the pairing indicator light B10 will be constantly on. When the RX module is in pairing state, press any button (B1-B8) on the TX end to perform pairing. After successful pairing, the pairing indicator light B10 will automatically turn off and exit the pairing state. If the pairing indicator light B10 stays on for 12 seconds and then automatically turns off to exit the pairing state, it indicates that the pairing timeout has occurred.

8. Circuit Design

8.1 Power Supply Design

- Please pay attention to the power supply voltage of the device, exceeding the recommended voltage range may cause function abnormally and permanently damage;
- Try to use a DC stabilized power supply, and the power ripple coefficient should be as small as possible; the power load when transmitting the maximum power needs to be also considered;
- The RF module needs to be grounded reliably, and try to reduce the loops in PCB layout (especially the loop between ANT Pin and GND Pin should be as short as possible); a good grounding can achieve better performance and reduce the impact of RF on other sensitive devices.

8.2 RF Routing Design

- The module should be far away from RF interference sources, such as high-frequency circuit

transformer, and please do not directly route at the lower layer of the RF module. Otherwise, the receiving sensitivity may be affected;

- When using the on-board antenna, the antenna needs to be clear on both sides, and the ground (copper foil) should not be too close to the antenna at the same time, otherwise it will absorb the radiated energy;
- Route 50Ω impedance line, lay the ground and add more via holes around it
- If there is enough space on your PCBA, please reserve a π -type matching circuit, and it needs to be placed as close to the chip end as possible, please make it grounded and add via holes around it. Do remember to connect it through a 0R resistor, otherwise the antenna will open circuit; SMA ANT circular through-hole requires clearance treatment

8.3 Antenna Design

- There are many types of antennas, please choose the appropriate antenna according to your needs;
- Choose a suitable position to place the antenna, according to the antenna polarity. And it is recommended to be vertically upward;
- There should be no metal objects in the antenna radiation path, otherwise the transmission distance will be affected (such as a closed metal casing).

8.4 Wireless Interference

For high-power wireless transmission, wireless interference may occur, which may affect the functions of some sensitive circuits, such as amplifiers, ADCs, RESETs, and data pins with low driving force. This situation has a significant impact on high-power transmission at 20dbm and above. The interference mainly comes from the antenna power being amplified and coupled to longer lines or devices through conduction or radiation. Therefore, when making the hardware design, the signal routing should be as short as possible; when using high power, try to use external antennas as much as possible, stay away from PCB sensitive devices, and add 100pF ground capacitance in sensitive device circuits to filter out high-frequency interference in low-speed signals to reduce wireless interference in other circuits.

9. Welding Operation Guidance

9.1 Reflow Soldering Curve Chart

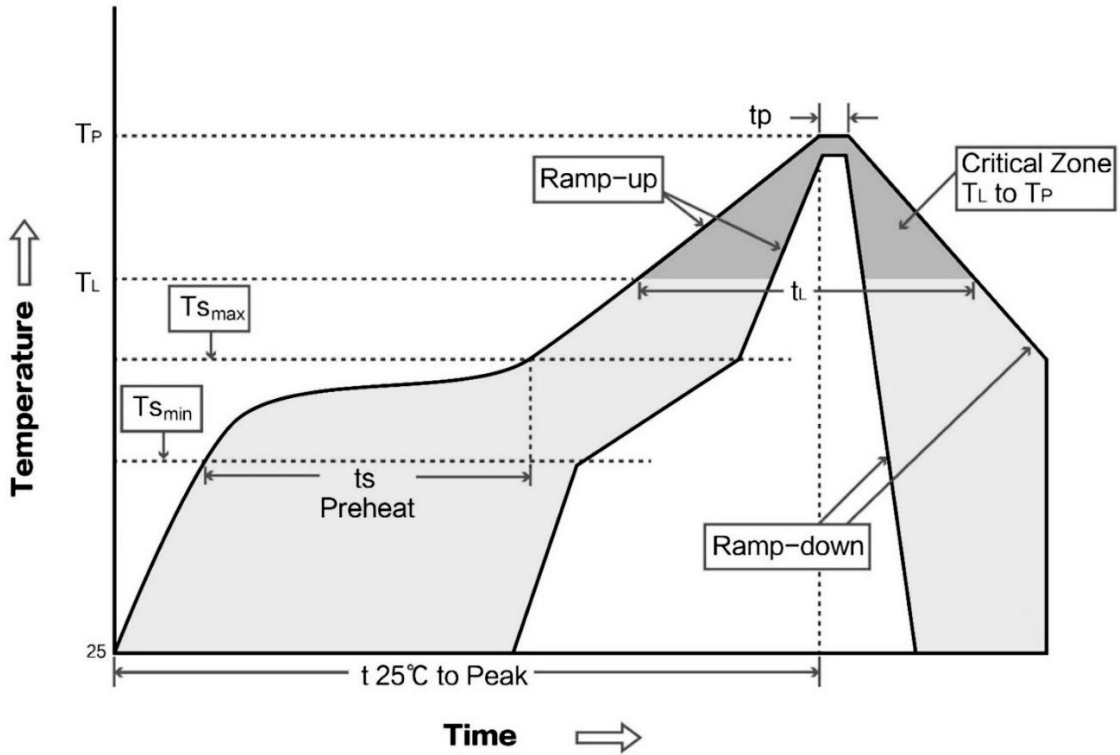

9.2 Reflow Soldering Temperature

IPC/JEDEC J-STD-020B the condition for lead-free reflow soldering	Big size components (thickness ≥ 2.5 mm)
The ramp-up rate (TL to Tp)	3°C/s (max.)
Preheat Temperature	
- Temperature Minimum (T _{smin})	150°C
- Temperature Maximum (T _{smax})	200°C
- Preheat Time (ts)	60~180s
Average ramp-up rate (T _{smax} to Tp)	3°C/s (Max.)
- Liquidous temperature (TL)	217°C
- Time at liquidous(tL)	60-150 second
Peak Temperature (Tp)	245+/-5°C

10. Notice for module application

- (1) This module is an electrostatic sensitive product. Please operate on an anti-static workbench during installation and testing;
- (2) When installing the module, make sure that nearby objects keep a sufficient safe distance from the module to prevent short-circuit damage;
- (3) Liquid substance is not allowed to come into contact with this module, and this module should be used in a dry environment;
- (4) Please use an independent voltage stabilizing circuit to supply power to this module, and avoid sharing with other circuits. The tolerance of the power supply should not be less than 5%.
- (5) The indicators of this module are accord to commonly used international standard. If special certifications needed, we can adjust certain indicators according to your needs.

11. Model Selection

Model No.	Frequency	Module Type
DL-A7149K8-RX433	433MHz	RF Receiver Module
DL-A7149K8-RX868	868MHz	RF Receiver Module
DL-A7149K8-RX915	915MHz	RF Receiver Module
DL-A7149K8-TX433	433MHz	RF Transmitter Module
DL-A7149K8-TX868	868MHz	RF Transmitter Module
DL-A7149K8-TX915	915MHz	RF Transmitter Module

12. Contact us

Shenzhen DreamLNK Technology Co., Ltd

Office Add.: 602-603, Bldg C, Zone A, Huameiju Plaza, Xihu Rd., Bao'an District, Shenzhen, Guangdong, China

Factory Add.: Huazhi Innovation Valley, No. 7 Yuhua Street, 138 Industrial Zone, Tangxia Town, Dongguan, Guangdong, China

TEL.: +86-755-29369047

FAX: +86-755-27844601

Mobile: +86-13760215716

E-mail: james@dreamlnk.com

Web. (CN): www.dreamlnk.com

Web. (EN): www.iot-rf.com