

## 2.4G Wireless Transceiver Module

# SPECIFICATION

Model No.: DL-297LX

Version: V1.0



Before using this module, please pay attention to the following important matters:

This module is an electrostatic sensitive product. Please operate it on an anti-static workbench during installation and testing.

The module is integrated with all RF related devices and has PCB onboard antenna, so excellent RF performance can be obtained without additional antenna configuration. Please do not use metal case above the antenna, otherwise it will lead to serious attenuation of radio frequency signals, which will affect the effective use of distance.

Metal objects and wires should be kept away from the antenna as much as possible.

When installing the module, nearby objects should be kept at a sufficient safety distance from the module to prevent short circuit damage.

This module should be used in a dry environment. Please do not make any liquid substance come into this module.

Please use an independent voltage regulator circuit to supply power to this module, and avoid sharing with other circuits. The tolerance of the power supply should not be less than 5%.

### **Limitations:**

This module is intended to be embedded in the customer's terminal product application, and does not provide a casing itself. It is not recommended that the customer directly resell this module as a final product without permission.

This series of modules are in accordance with commonly used international standards. If there is any special certification needed, we can adjust certain indicators according to your needs.

This module cannot be applied to life rescue, life-support systems, or any occasion where personal injury or life threatening may cause by equipment failure. Any organization or individual carrying out the above-mentioned applications shall bear all risks at their own.

### File version & update management

DATE	Software Version	Remarks
2013-6-5	V1.0	Standard DL-297LD 2.4G module
2015-4-8	V1.1	Upgrade DL-297LA module with on-board antenna

## 1. Brief Introduction

DL-297L series modules are low-power, high bandwidth wireless digital communication modules working in the 2.400-2.483ghz world-wide ISM band. The module has the characteristics of low cost, small size, stable work and good product consistency. The maximum transmission rate can reach 2Mbps. It can be widely used in the situations where wireless connection is needed in daily life. It can also be used in industrial control, access control, attendance, monitoring and security industries. DL-297LD-C series wireless communication modules can be divided into multiple models according to whether they are equipped with MCU, whether they are equipped with power amplification, data interface and packaging mode. Various models in the same series can communicate with each other. All models are advanced in design, with excellent technical indicators, in line with the parameter requirements of FCC specifications, and can meet the certification needs of customers.

## 2. Features

- Efficient 4-pin SPI interface;
- Support 1Mbps, 2Mbps wireless transmission rate, high data throughput;
- Modulation by FSK / GFSK;
- Output power of programmable control: 9-35dbm
- Receiving sensitivity: -88dbm at 2Mbps, and the reliable transmission distance can reach 100m (open air);
- Programmable carrier frequency: 2400-2483.5mhz, 83 frequency bands are optional;
- Flexible configuration of multiple communication channels, and fast frequency point switching can meet the needs of frequency hopping system;
- Ultra-low power consumption
- Receiving current < 17.5mA
- Transmission current < 14mA
- Sleeping current < 3uA;
- Data buffer, burst data transmission, with automatic receiving response and retransmission processing;
- Support 1-to-6 data communication channel connection;
- Powerful digital features, low-cost MCU can be used to get high-performance RF system;

## 3. Typical application

- Wireless toys, Wireless game handles
- Wireless audio and video transmission, wireless headset
- Child finder and tracker

- Medical devices and remote controls
- Logistics tracking, warehouse inspection, RFID, etc
- Consumer electronic wireless applications
- Low power remote sensing and telemetry
- Wireless sensor network applications

#### 4. External Control

DL-297L series is equipped with slave SPI interface, which can access and set its register and FIFOs through the main control MCU. Four wire SPI (CSN, SCK, MoSi, MISO) provides a high-speed interface with SCK reaching 8MHz.

#### 5. Parameters

Working frequency: 2.4Ghz

Modulation mode: FSK / GFSK

Transmitting power: 0dbm (1mW)

Receiving sensitivity: - 88dbm

Transmission rate: 1Mbps / 2

Emission current < 14mA

Receiving current < 23mA

Standby current < 3uA

Working channel: 83 frequency band selection

Data interface: SPI interface

Communication distance: 0-50m (0dbm, 2m speed, visual distance)

Antenna impedance: 50Ω

Operating temperature: - 40-85 ° C

Power supply: DC 1.9V ~ 3.

#### 6. Pins Definition

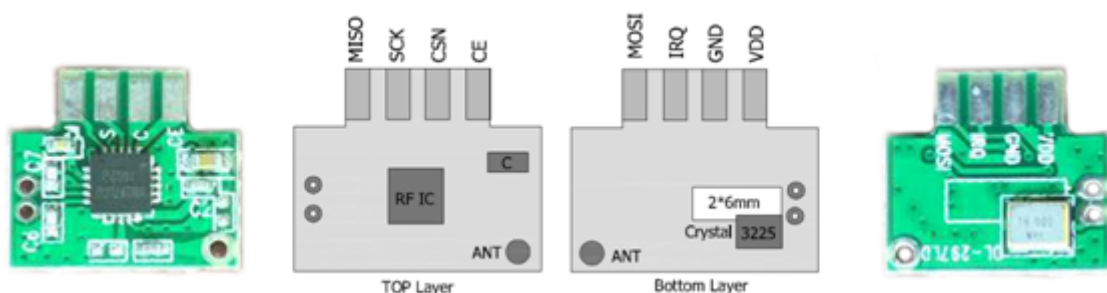

Pin	Definition	Function	Remark
1	VDD	Power Supply: 3V	RF VDD
2	GND	Grounding, common ground with the system	
3	IRQ	Interrupt signal	
4	MOSI	SPI data input, MOSI	
5	CE	Mode chip selection signal	
6	CSN	SPI chip select signals	
7	SCK	SPI Clock signals	
8	MISO	SPI data output, MISO	

Pin Definition of DL-297L series modules

\*Note 1: the receiving sensitivity of channels with integral multiples of 16mhz crystal oscillator (such as 2416, 2432mhz, etc.) and adjacent channels with plus or minus 1MHz is degraded by 2dB; the transmitting signal modulation accuracy (EVM) is degraded by 10%.

\*Note 2: the maximum length of transmitted data is 16 bytes in 250kbps mode.

## 7. Product Size

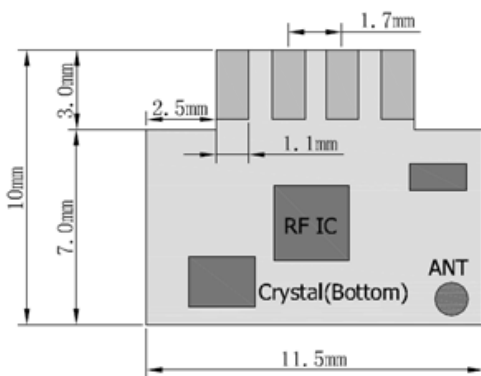

DL-297LA Dimension

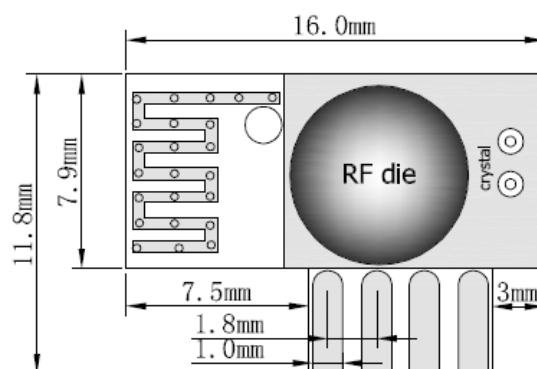

DL-297LA Dimension

## 8. Sample program settings

### 8.1 General program configuration process

#### 8.1.1 Receiving mode configuration process

The following procedures start with sleeping mode (chip reset) after power on again

NO	Action	Address
1	Power on defaults to sleep mode	
2	Clear RX FIFO and status register	0x07
3	Set the rf_cal、bb_cal、demo_cal register	0x1E、0x1F、0x19
4	Open receive channel n ( 0-5 )	0x02
5	Set the address width (3-5 bytes) and address of channel n	0x03、0x0A ~ 0x0F
6	Set working frequency point	0x05
7	Set transmission power, receiving low noise discharge current, and data rate mode	0x06
8	Select communication mode: with automatic retransmission, retransmission times, retransmission delay, with automatic response	0x04、0x01
9	If it is a static payload, you need to set the payload length	0x11 ~ 0x16
10	If it is a dynamic payload, read the payload according to the dynamic payload length	0x1D、0x1C
11	Set config register, control CE pin to high, enter receiving mode	0x00

Table 1: Receiving mode configuration process

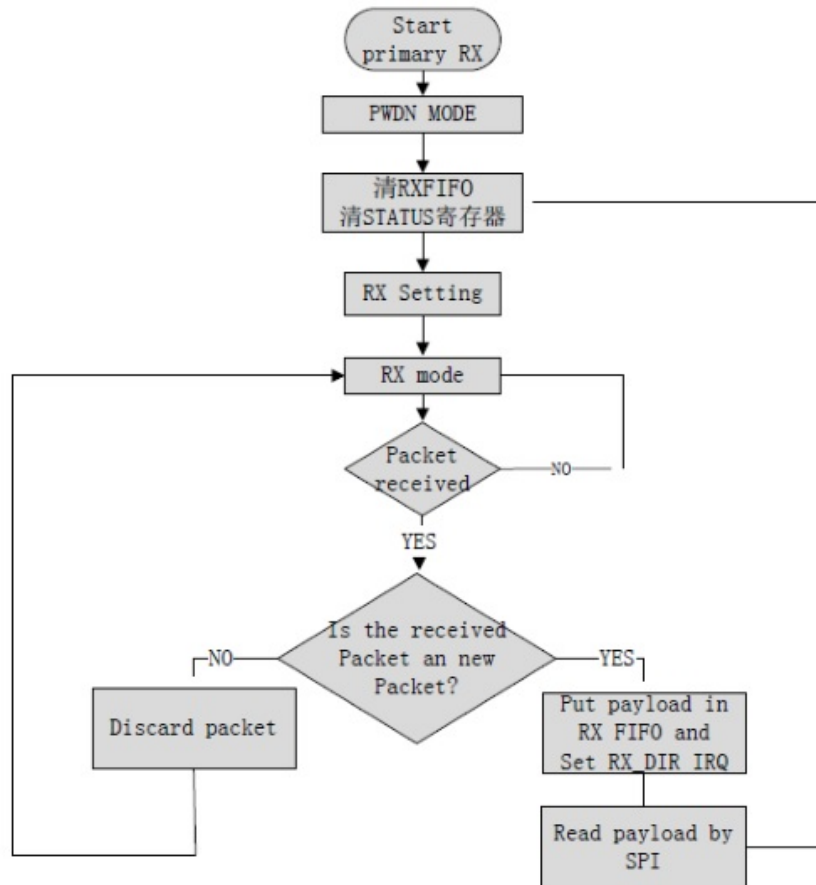

Workflow for the Receiver

### 8.1.2 Transmitting mode configuration process

NO	Action	Address
1	Power on defaults to sleep mode	
2	Clear TX FIFO and status register	0x07
3	Set the rf_cal、bb_cal、demo_cal register	0x1E、0x1F、0x19
4	Set address width (3-5 bytes) and address of transmission channel	0x03、0x10
5	Set working frequency point	0x05
6	Set transmission power, receiving low noise discharge current, and data rate mode	0x06
7	Select communication mode: with automatic retransmission, retransmission times, retransmission delay, with automatic response	0x04、0x01
8	Write TX payload	
9	Set the config register to control the CE pin to a high pulse waveform	0x00

Table 2: Transmitting mode configuration process

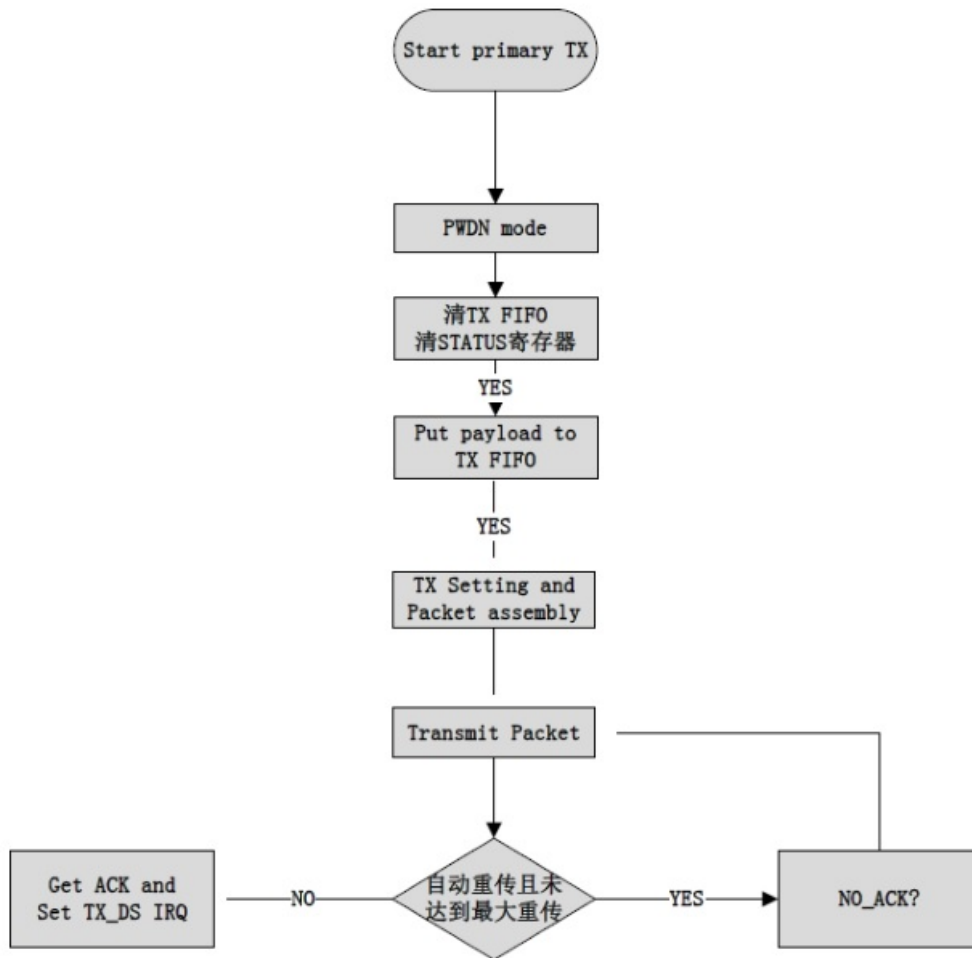

Workflow for the Transmitter

## 8.2 Configuration flow of single carrier mode

Single carrier mode is mostly used to judge the function and performance of hardware

NO	Action	Address
1	Power on defaults to sleep mode	
2	Set the rf_cal、bb_cal、demo_cal register	0x1E、0x1F、0X19
3	Set the transmitting mode, transmit power and working frequency	0x00、0x06、0x05
4	CE pin pulled low, SCK and MOSI pin pulled high	

Table 3: Configuration flow of single carrier mode



### 8.3 Special register configuration

The internal registers of DL-297L Series B include general registers and special registers. General registers include registers compatible with other chips, such as "RF\_SETUP" . The special registers are unique to DL-297LD-B, and are divided into as below:

**"BB\_CAL(address:0x1F)" ; " DEM\_CAL(address:0x19)" ; " RF\_CAL(address:0x1E)"**

BB\_ CAL is a state machine related register.

DEM\_ CAL is a register related to modulation and demodulation.

RF\_ CAL is a register related to RF transceiver.

#### 8.3.1 2M mode communication configuration

BB\_ CAL : {0xCD, 0x3F, 0x7F, 0x9C, 0x20}

DEM\_ CAL : {0x0B, 0xDF, 0xC4, 0xA7, 0x03}

RF\_ CAL : {0xC9, 0x9A, 0xB0, 0x79, 0xBB, 0xAB, 0x9C}

- ◆ The communication time with response is about 1.6 Ms.
- ◆ the single communication time without response is about 0.8ms.
- ◆ the above configuration is for packet length of 8 bytes.
- ◆ when the packet length is 8-32byte, modify BB\_ CAL : {0xEA,0x3F,0x7F,0x9C,0x20}.
- ◆ RF\_SETUP is recommended to configure as 0x0D, and transmit power of 8dbm (it can pass safety certification)

#### 8.3.2 1M mode communication configuration

BB\_ CAL : {0xCD, 0x3F, 0x7F, 0x9C, 0x20}

DEM\_ CAL : {0x0B, 0xDF, 0xC4, 0xA7, 0x03}

RF\_ CAL : {0xDA, 0x9A, 0xB0, 0x79, 0xBB, 0xAB, 0x9C}

- ◆ the communication time with single response is about 1.7ms.
- ◆ the single communication time without response is about 0.85ms.
- ◆ the above configuration is for packet length of 8 bytes.
- ◆ when the packet length is 8-32byte, modify BB\_ CAL : {0xD1,0x3F,0x7F,0x9C,0x20}.
- ◆ RF\_SETUP is recommended to configure as 0x05 , and transmit power of 8dbm (it can pass safety

certification)

### 8.3.3 Single carrier mode configuration

BB\_CAL : {0xCD, 0x3F, 0x7F, 0x9C, 0x20}

DEM\_CAL : {0x0B, 0xDF, 0xC4, 0xA7, 0x83}

RF\_CAL : {0xDA, 0x9A, 0xB0, 0x79, 0xBB, 0xAB, 0x9C}

## 8.4 RSSI application and register configuration

RSSI is used to indicate the strength of the received signal. Register "RSSI\_EN" and "RSSI\_SEL" are set to high, "DATAOUT\_SEL" is set to low, the value of RSSI can be read out from the register DATAOUT. The lower four bits of DATAOUT indicate the signal strength of the received data, and the higher four bits of DATAOUT indicate the strength of the interference signal before receiving the signal

## 8.5 Short distance communication configuration

The communication test is based on the RF demo board as the test result of the transceiver.

### **2M mode communication:**

Communication distance > 30m (transmitting power 8dbm, receiving sensitivity - 85dBm)

RF\_SETUP : 0x0D

RF\_CAL : {0xC9,0x9A,0xB0,0x79,0xBB,0xAB,0x9C}

Communication distance 0.5m (transmitting power - 20dbm, receiving sensitivity - 65dbm)

RF\_SETUP : 0x08

RF\_CAL : {0xC9,0x82,0xB0,0xE1,0xBB,0xAB,0x9C}

### **1M mode communication:**

Communication distance > 30m (transmitting power 8dbm, receiving sensitivity - 88dBm)

RF\_SETUP : 0x05

RF\_CAL : {0xDA,0x9A,0xB0,0x79,0xBB,0xAB,0x9C}

Communication distance 1m (transmitting power - 20dbm, receiving sensitivity - 68dbm)

RF\_SETUP : 0x00

RF\_CAL : {0xDA,0x82,0xB0,0xE3,0xBB,0x83,0x9C}

### 9. Module Connection Diagram (TTL Level)

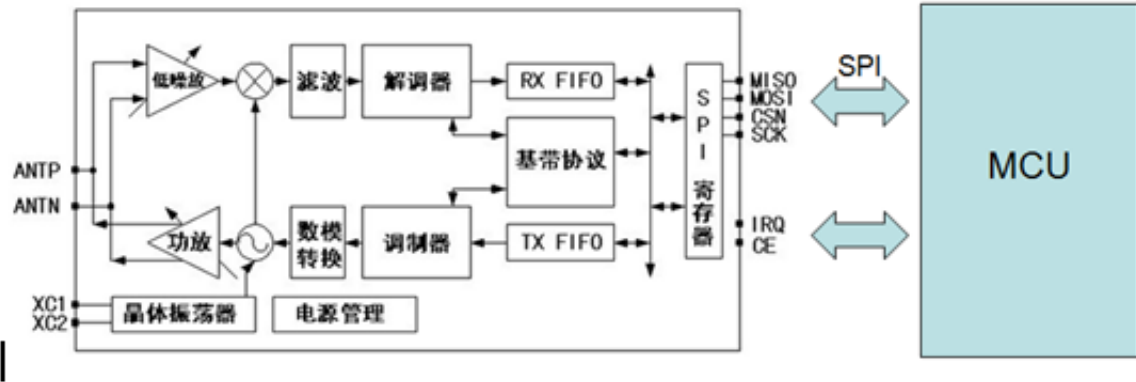

Module connection diagram

### 10. Applications



### 11. Module Assembly Diagram

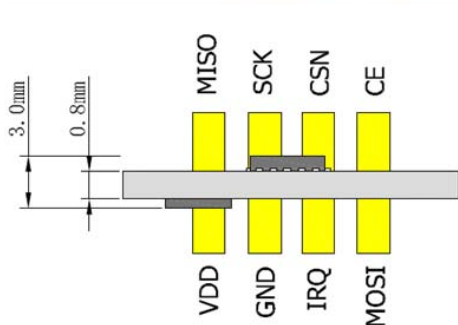
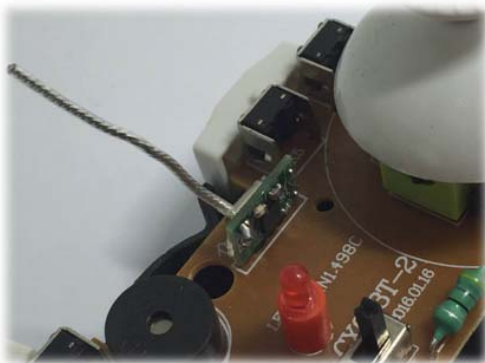

Top view of module direct assembly

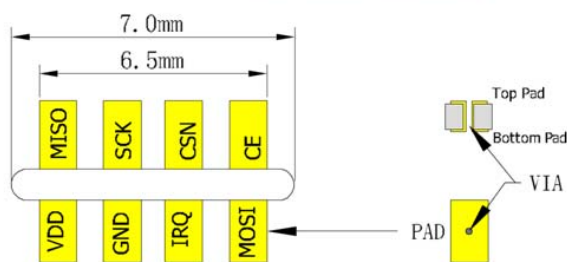

PCB main board slot size

## 12. Model Selection

Model	MOQ	Remark
DL-297LD	3K pcs	Package plate without antenna
DL-297LA	10K pcs	Binding version, PCB on-board-antenna

## 13. Contact us

Shenzhen DreamLnk Technology Co., Ltd

★ Data collection, Smart home, Internet of Things applications, Wireless remote-control technology, Remote active RFID, Antennas ★

Office Add.: Room 603, Unit C, Zone A, Huameiju Business Center, Xinhua Rd., Bao'an District, Shenzhen, Guangdong Province, China

Factory Add.: 5th Floor, Building B, Huazhi Innovation Valley, No. 7 Yuhua Street, 138 Industrial Zone, Tangxia Town, Dongguan, Guangdong Province, China

TEL.: +86-755-29369047

FAX: +86-755-27844601

Mobile: +86 13760215716

Wechat: wsj\_james

E-mail: [james@dreamlnk.com](mailto:james@dreamlnk.com)

Web: [www.iot-rf.com](http://www.iot-rf.com)