

RF LAYOUT

Application Guide

Version: V2.2

Date: Apr. 10th, 2022

www.iot-rf.com

This document provided by DREAMLNK is mainly used to guide your RF design base on our RF modules. The specifications and parameters provided here are just for your reference, hope it can help you in some way on your future product design.

DREAMLNK does not assume any responsibility for personal injury or property loss caused by improper operation. Prior to this declaration, DREAMLNK reserves the right to update this document in the future. And if you need any help on RF modules, or relative Antennas, please feel free to contact us, with contact details are shown as below:

SHENZHEN DREAMLNK TECHNOLOGY CO., LTD

Add.: 602-603, Bldg C, Zone A, Huameiju Plaza, Xinhua Rd., Bao'an District, Shenzhen 518101, Guangdong, China

Skype: wsj.james ;

Wechat: wsj_james

Mobile: +86-13760215716;

E-mail: james@dreamlnk.com

Web (CN): www.dreamlnk.com

Web (EN): www.iot-rf.com



Notice: The copyright of this document belongs to SHENZHEN DREAMLNK TECHNOLOGY CO., LTD, and any person who reproduce it without permission will bear the legal responsibility.

Copyright © SHENZHEN DREAMLNK TECHNOLOGY CO., LTD. 2022.

Document Revision History

Version	Date	Approved by	Revision of Contents
1.0	2014-08-08	Knight Ai	Original Version
2.0	2016-09-20	Tim Wang	1.New template adopted 2.Update the module reference schematic
2.1	2020-03-18	Fagan Xu	Add description of applicable modules
2.2	2022-04-10	Fagan Xu	Update Figure 6 (PCB LAYOUT Instance Diagram)

Contents

Document Revision History	2
Contents	3
Image Indexing	4
1 Foreword	5
2 Suggestions on Schematic Diagram of RF Interface.....	6
3 Structure Design of Coplanar Waveguide with 50Ω Impedance	7
4 Example and Precautions of Coplanar Waveguide PCB LAYOUT	9
5 Supplementary Instruction	10

Image Indexing

Figure 1: Reference Schematic Diagram of the RF Module	6
Figure 2: Coplanar Waveguide Structure Diagram	7
Figure 3: LAYOUT Diagram of Two Layers PCB	8
Figure 4: LAYOUT Diagram of Four Layers PCB (Reference Grounding is the 3 rd Layer).....	8
Figure 5: LAYOUT Diagram of Four Layers PCB (Reference Grounding is the 4 th Layer).....	8
Figure 6: PCB LAYOUT Instance Diagram	9

1. Foreword

This document mainly introduces the PCB Layout precautions of the RF circuit, which is surrounding the RF module. The main purpose is to help you correctly design the PCB routing when using our RF modules, so as to ensure the RF performance and reduce the design cycle of the products.

This INSTRUCTION is applicable to all the Sub-GHz and 2.4GHz RF modules produced by DreamLNK, which include 433/868/915MHz RF modules, 2.4G RF modules, FSK transceiver modules, Bluetooth modules, LoRa modules, UART module, etc.

You may visit our website (www.iot-rf.com) to know more about our RF modules! If any product meets your demand, please feel free to contact James Wu (james@dreamlnk.com)

2. Suggestions on Schematic Diagram of RF Interface

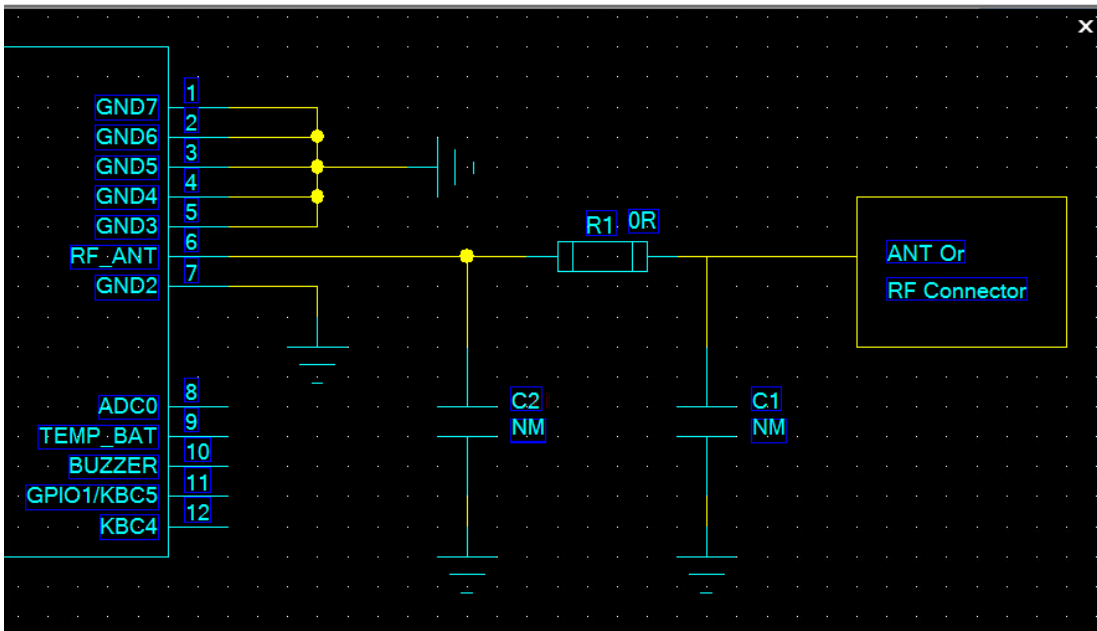

Figure 1: Reference Schematic Diagram of the RF Module

Note: C1, R1 and C2 are reserved matching circuits to optimize the RF performance of the antenna. The default value is: R1 = 0R Resistance; C1 = NC; C2 = NC

Remark:

1. Please reserve a π -matching circuits as above on your PCBA, for eventual RF performance optimization in antenna design.
2. Sensitive IC should be away from RF module or shielding
3. Pay attention to antenna directionality. Normally the antenna should be vertical stand on the base board.
4. The product shell (especially above antenna part) shall not be electroplated, or metal material

3. Structure Design of Coplanar Waveguide with 50Ω Impedance

It is recommended to adopt coplanar waveguide microwave transmission form with characteristic impedance of 50Ω, as shown in Figure 2 as below:

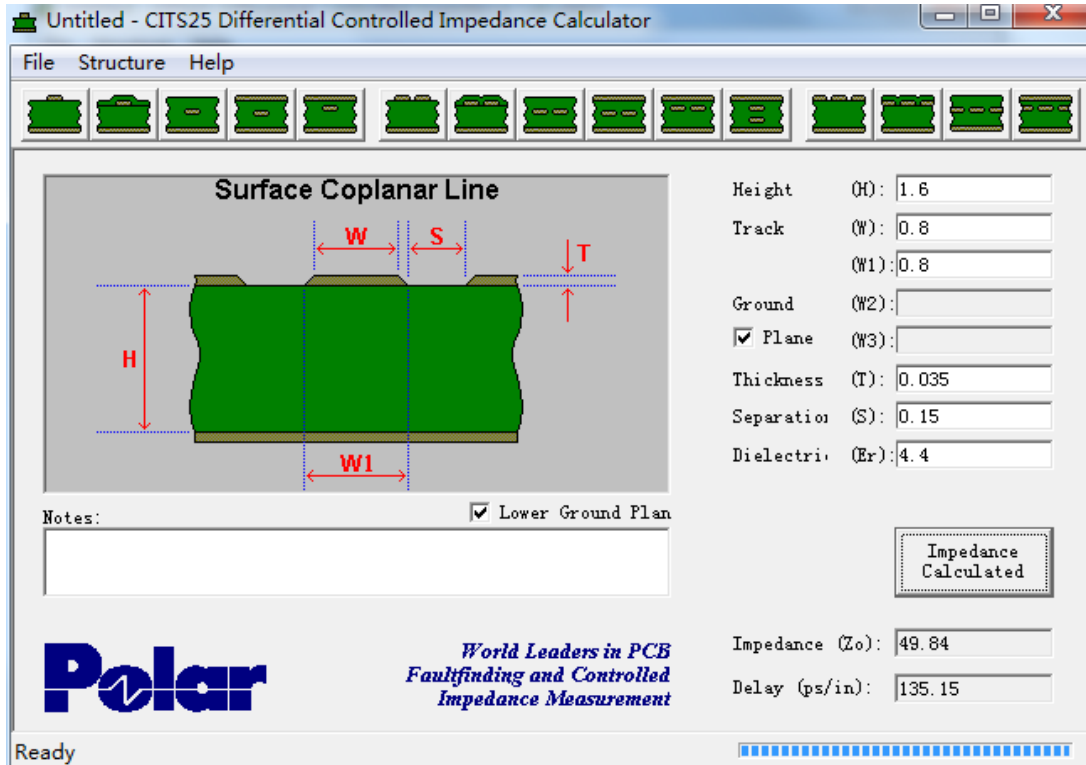

Figure 2: Coplanar Waveguide Structure Diagram

The main factors affecting the characteristic impedance of coplanar waveguide include the Dielectric Constant of Substrate (usually 4.2~4.6, here is 4.4), Height between Signal Layer and Reference Ground Layer (H), Microstrip Linewidth (W), Ground Clearance (S) and Copper Foil Thickness (T).

Table 1 lists the recommended Microstrip Linewidth (W) and Ground Clearance (S) corresponding to 50ohm impedance, with height between different Signal Layers and Reference Ground Layers (H), as well as the Copper Foil Thickness (T) = 0.035mm

Table 1: Recommended Values for Coplanar Waveguide with 50Ω Impedance

Height between Signal Layer and Reference Ground Layer (H)	Microstrip Linewidth (W)	Ground Clearance (S)
0.076mm	0.1188mm	0.15mm
0.1mm	0.1623mm	0.2mm
0.15mm	0.24mm	0.2mm

0.8mm	0.8mm	0.18mm
1.0mm	0.8mm	0.17mm
1.2mm	0.8mm	0.16mm
1.6mm	0.8mm	0.15mm
2mm	0.8mm	0.14mm

If it is a 2-layer PCB, the signal layer is the Top layer and the Reference Ground Layer is the Bottom layer, as shown in Figure 3 below. If it is a 4-layer PCB, the Reference Ground Layer can be the second layer, the third layer or the fourth layer. If the Reference Ground Layer is the third layer, the second layer directly below the signal layer shall be prohibited from paving, and the width of the prohibited area shall be at least 5 times of the signal linewidth, as shown in Figure 4 below. If the Reference Ground Layer is the 4th layer, the 2nd and 3rd layers directly below the signal layer shall be prohibited from paving, and the width of the prohibited area shall be at least 5 times of the signal linewidth, as shown in Figure 5 below. If it is a 6-layer PCB, the above rules are similar...

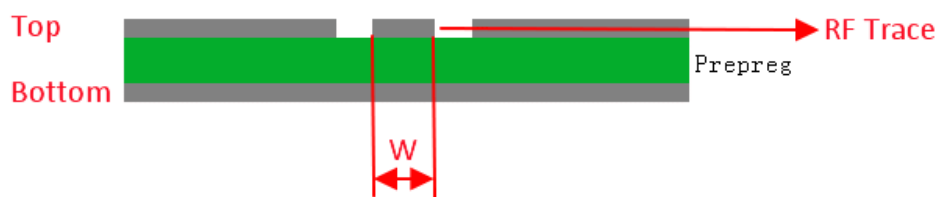

Figure 3: LAYOUT Diagram of Two Layers PCB

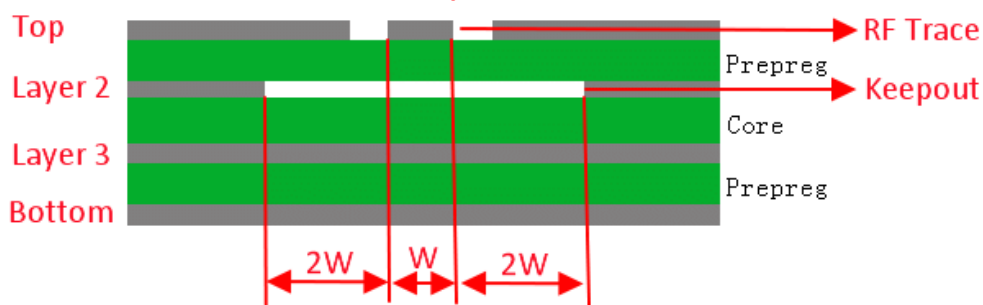

Figure 4: LAYOUT Diagram of Four Layers PCB (Reference Grounding is the 3rd Layer)

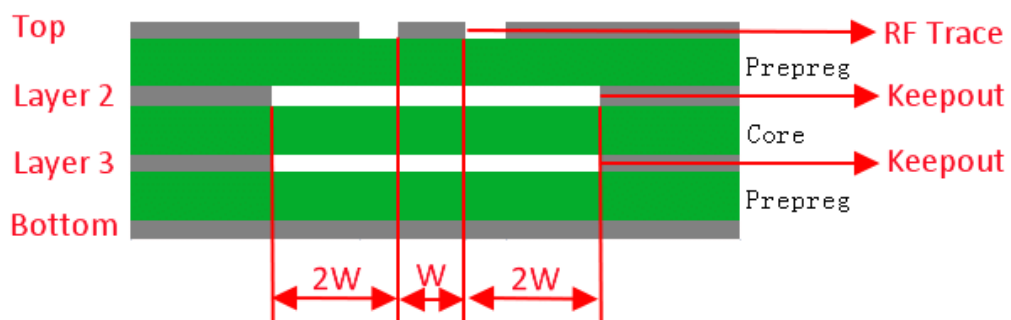

Figure 5: LAYOUT Diagram of Four Layers PCB (Reference Grounding is the 4th Layer)

4. Example and Precautions of Coplanar Waveguide PCB LAYOUT

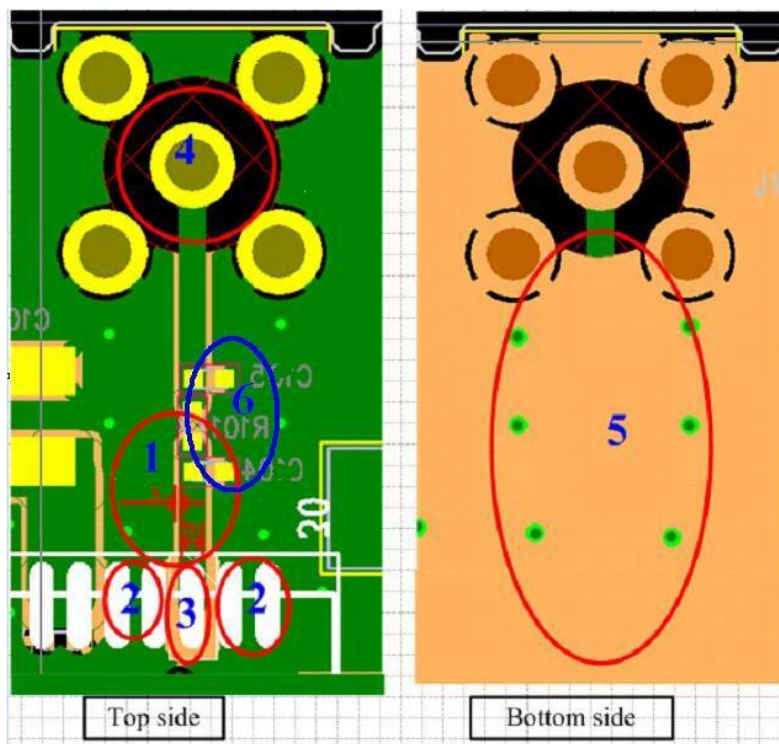

Figure 6: PCB LAYOUT Instance Diagram

Referring the above figure with the numeric symbol, there are six tips to note:

- 1) Strictly control the Microstrip Linewidth (W) and Ground Clearance (S) corresponding to 50-ohm coplanar waveguide. For example, with the common PCB plates as FR4 media (dielectric constant 4.2) and copper coating thickness 35um, the Microstrip Linewidth (W) and Ground Clearance (S) corresponding to the different signal layers are shown in Table 1. It is particularly reminded that PCB factories need to control Microstrip Linewidth (W) and Ground Clearance (S) accuracy.
- 2) The PIN here is no need to do a thermal pad, but should be in full contact with the ground.
- 3) The surface layer is paving forbidden (slightly) to reduce Parasitic Effects. The RF line should be as short as possible, and it is best to avoid routing at right angles. If there is a corner, it is recommended to go 135 degrees.
- 4) When connecting the components package, it should be noted that the signal pin should be kept at a certain distance from the ground. Refer to Figure 6. Please do not lay copper at the bottom of the signal pad.

- 5) Please ensure the integrity of the reference ground layer corresponding to the RF routing, and increase the grounding hole to help the RF return, and keep the distance between the ground hole and the signal line at least twice the line width. Ensure that the grounding area of the same layer of RF line is as large as possible, the reference ground of the other side should be also as complete as possible, and ensure that a certain number of ground holes are connected to two layers of ground.
- 6) The π type matching circuit is normally constituted of 3 components (as shown in Figure 1). When designing, the pad should be placed close to the antenna (as shown in the above figure 6). If the space between the antenna connector (SMA) and the RF pin of the module is not enough (impossible to place the three components of the π matching circuit), it can be changed to an L-shaped matching circuit.

5. Supplementary Instruction

5.1 Regarding the RF front-end hardware module with SPI interface, please note that: it needs to be connected to the MCU on the motherboard. Please refer to the Pin Definition in our RF module specification sheet to know more, when making the design.

5.2 Here is an experimental formula to calculate the Microstrip Lines:

$$Z (\text{Microstrip}) = \{87/[\text{sqrt}(\text{Er}+1.41)]\} \ln[5.98\text{H}/(0.8\text{W}+\text{T})]$$

Note: W is the Microstrip linewidth, T is the copper foil/plate thickness (of the microstrip lines), H is the Height between Signal Layer and Reference Ground Layer, and Er is the dielectric constant of the PCB board material.